

Key Features

- Pre-assembled kit ready for instant use
- Foldable screen with the movable flight case for easy delivery
- Built-in stand with motorized height adjustment
- Impressive audio from Harman Kardon speakers
- Seamless large display for rental at any event/exhibition



Product Description

The ViewSonic® LDS135-151 is a 135" All-in-One Direct View LED Display Solution Kit that boasts instant use, easy delivery, and convenient maintenance, making it an ideal rental-ready solution for events, exhibitions, or any other short-term usage. The pre-assembled design and built-in motorized height adjustment stand enables effortless set up within just a few minutes. Delivery convenience is greatly enhanced with the new foldable screen design, reducing the packaging size of the movable flight case by nearly 50% compared to the previous generation, thus minimizing shipping costs. With the seamless large screen and superior built-in Harman Kardon speakers, be ready to impress your audience everywhere from high-end board rooms and receptions to galleries, auditoriums, and other large venues.

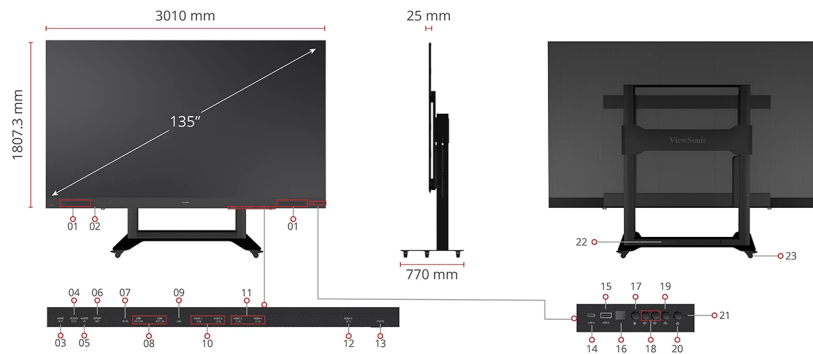

1. Harman Kardon Speakers
2. Power Button
3. HDMI Out
4. Audio Out
5. Audio In
6. S/PDIF Out
7. IR In

8. USB 2.0 (5V/1.5A) x 2
9. LAN & Control
10. HDMI 2.0 x 2
11. HDMI 1.4 x 2
12. HDMI 2.1
13. RS232
14. USB-C (5V/2A)

15. USB 2.0 (5V/1.5A)
16. IR Receiver
17. Menu Control: Brightness Level
18. Menu Control: Volume
19. Menu Control: Input Source
20. Power Button
21. Indicator Light

22. Control Panel: Height Adjustment
23. 360° Silent Wheels

Visit Us

www.viewsonic.com

SPECIFICATION

Screen Size:	135"
Display Area (mm):	3000 (H) x 1687.5V)
Native Resolution:	1920x1080
Panel Technology:	Direct view LED
LED Package Type:	SMD 3 in 1
Bonding Wire:	Gold
Pixel Pitch (mm):	1.56
Refresh Rate:	4440Hz
Brightness (max.):	600 nits (8 levels adjustable)
Contrast Ratio (typ.):	6000:1
Orientation:	Landscape
Viewing Angles (typ.):	H = 160, V = 160
LED Lifetime (typ.):	100,000 Hours
Local Storage:	Total 64GB (56GB available storage)
Embedded OS:	Android 9.0
Resolution Support:	VGA(640 x 480) to 1080p(1920 x 1080)
HDTV Compatibility:	480i, 480p, 576i, 576p, 720p, 1080i, 1080p, 2160P/60Hz
Horizontal Frequency:	23-120 kHz
Vertical Scan Rate:	15-135 Hz

INPUT

HDMI:	x6 (HDMI 2.1 x 1, HDMI 2.0 x 2, HDMI 1.4 x 2, HDMI 2.0 internal x1)
USB Type A:	x3 (USB2.0 x3)
RJ45 Input (Internet):	x1
IR in:	x1
Wi-Fi Input:	2.4G/5G Hz
USB Type C:	x1 (Video input, Power output (5V/2A))
Audio-in (3.5mm):	x1

OUTPUT

HDMI out:	x2 (HDMI 2.0 external x1,internal x1)
Speaker:	20W x2 (Harman Kardon)
Audio out (3.5mm):	x1
USB Type A (Power):	Shared with USB input (5V/1A x3)

CONTROL

RJ45 (LAN control):	x1(shared with internet)
USB Type A (Services):	x1(shared with USB A input)
RS232 (DB 9-pin female):	x1
IR Receiver:	x1

OTHERS

Power Supply Voltage:	100-120V/30A~ 50/60Hz or 220-240V/15A~ 50Hz (vary by country)
Power Consumption:	1200W (typ), 2300W (max) < 0.5W (Sleep), < 0W (Off)
Operating Temperature:	0~40°C
LED Module Quantity:	100
Ingress Protection Rating:	IP30
Net Weight:	496 lbs (225 kg)
Gross Weight:	728 lbs (330 kg)
Screen Dimensions (WxHxD):	1800x1948x770 mm(min.) 3010x2598x770 mm(max.)
Packing Dimensions:	74.8x80x31.5 inches (1900x2032x800 mm)

STANDARD ACCESSORIES

Power Cord:	x1
LAN Cable (Cat 5A):	x1 (5m)
IR Extender Cable:	x1(3m)
Remote Control:	x1
QSG:	x1
Spare Parts:	LED PCB Unit x7
Maintenance Tool:	LD-MK-001 x1

OPTIONAL ACCESSORIES

Maintenance Tool:	LD-MK-001
ViewBoard Cast Button(USB-C):	VB-WPS-001
ViewBoard Cast Button(USB-A+HDMI):	VB-WPS-003